



An Effective Power Quality Improvement of Integration of Renewable Energy source to the Grid

T. Vani*1, VenuGopal Reddy Bodha*2

M.Tech Student, Dept of EEE, SVEC, Suryapet, Hyderabad, Telangana state, India
Assistant Professor, Dept of EEE,SVEC, Suryapet, Hyderabad, Telangana state, India

ABSTRACT:

This paper presents a renewable energy sources utilization and its grid penetration in electrical grids are spread out in worldwide. The generated wind power is always getting fluctuations due to the time varying of nature problems, will effect on electrical network power quality and reliability. The integration of renewable energy sources to the grid in between to design voltage source converter it will rectify the fluctuations and pass to the electrical grid quality of power. The power quality measurement means active power, reactive power, voltage sag, voltage swell, flicker, harmonics and behavior of electrical sources switching operation is measured. In this paper used FACT's devices with battery energy storage system can be reduced the power quality problems. The STATCOM control technique is for grid connected wind energy device to improve the power quality system is designed by using MATLAB/SIMULINK.

I. INTRODUCTION

In recent years, wind energy has become one of the most important and promising sources of renewable energy, which demands additional transmission capacity and better means of maintaining system reliability. To have sustainable growth and social progress, it is necessary to meet the energy need by utilizing the renewable energy resources like wind. The need to integrate the renewable energy like wind energy into power system is to make it

possible to minimize the environmental impacts. Wind energy conversion systems are the fastest growing renewable source of electrical energy having tremendous environmental, social, and economic benefits [1].Power Quality is defined as power that enables the equipment to work properly. A power quality problem can be defined as any deviation of magnitude, frequency, or purity from the ideal sinusoidal voltage waveform. Good power quality [2] is benefit to the operation of electrical equipment, but poor power quality



will produce great harm to the power system. However, the generated power from wind energy conversion system is always fluctuating due to the fluctuation nature of the wind. Therefore injection of the wind power into an electric grid affects the power quality. The important factors to be considered in power quality measurement are the active power, reactive power, variation of voltage, flicker, harmonics, and electrical behavior of switching operation [3].

In this proposed scheme Static Synchronous Compensator (STATCOM) is connected at a point of common coupling with a battery energy storage system (BESS) to mitigate the power quality issues. Therefore STATCOM [4] provides Reactive Power support to wind generator and load. The battery energy storage is integrated to sustain the real power source under fluctuating wind power. The STATCOM control scheme for the grid connected wind energy generation system for power quality improvement is simulated using MATLAB/SIMULINK in power system block set.

II. RELATED WORK

A. Power quality standards, issues and its consequences

1) **International electro technical commission guidelines:** Some guidelines of measurements and norms are specified under IEC 61400 standard which determines the power quality of wind turbines.

The standard norms are specified.

- 1) IEC 61400-21: Measuring the power quality characteristic of grid connected wind turbine.
- 2) IEC 61400-13: Wind Turbine — measuring procedure in determining the power behavior.
- 3) IEC 61400 – 3 - 7: Measures the emission limits for fluctuating load and IEC 61400-12: Wind Turbine performance.

2) Harmonics: It is due to the operation of power electronic converters. Harmonic voltage and current should be in limited as per the IEC-61400-36 guideline. The rapid switching gives a large reduction in lower order harmonic current and higher order harmonics are filtered out by using filters.

3) VOLTAGE VARIATION: This is due to the fluctuations in the wind turbine due to wind. The voltage variation is directly related to real and reactive power variations. The voltage variation is commonly classified as under:

- Voltage Sag/Voltage Dips.
- Voltage Swells.
- Short Interruptions.
- Long duration voltage variation.

The voltage flicker issue describes dynamic variations in the network caused by wind turbine or by varying loads. Amplitude of voltage fluctuations depends on grid strength, network impedance, and phase angle and power factor of wind turbine. During voltage variations frequency is in the



range 10–35 Hz. The IEC 61400 – 4 - 15 specifies a flicker meter that can be used to measure flicker directly.

4) WIND TURBINE LOCATION IN POWERSYSTEM:

It is located where the power quality is highly influenced. Its operation and its influence on the power system depend on the structure of the network.

5) SELF EXCITATION OF WIND TURBINE GENERATING SYSTEM:

The self-excitation of wind turbine generating system (WTGS) arises a risk equipped with commutating capacitor. It provides the reactive power compensation to the induction generator.

The disadvantages of self- excitation are the safety aspect and balance between real and reactive power.

6) CONSEQUENCES OF THE ISSUES:

Voltage variations, voltage flicker, harmonics causes the malfunctions of equipments. It leads to tripping of protection devices, damaging the sensitive equipments. Overall it degrades the power quality in the grid.

B. GRID COORDINATION RULE

American Wind Energy Association (AWEA) led the effort to develop its own grid code for stable operation as per IEC-61400-21 for the interconnection of wind plants to the utility systems, after the block out in United State in August 2003. According to these, operator of transmission grid is responsible for the

organization and operation of interconnected system.

1) Voltage rise (u) The voltage rise at the point of common coupling can be approximated as a function of maximum apparent power S_{max} of the turbine, the grid impedances R and X at the point of common coupling and the phase angle ϕ , given in Eq. 1.

$$\Delta u = \frac{S_{max} (R \cos \phi - X \sin \phi)}{u^2} \quad (1)$$

Where Δu —voltage rise,

S_{max} —max. apparent power,

ϕ —phase difference,

U —nominal voltage of grid.

The Limiting voltage rise value is <2 %

2) Voltage dips (d) The voltage dips is due to startup of wind turbine and it causes a sudden reduction of voltage. It is the relative % voltage change due to switching operation of win turbine. The decrease of nominal voltage change is given in Eq. 2.

$$D = K_u s_n / s_k \quad (2)$$

Where d is relative voltage change, s_n is rated apparent power, s_k is short circuit apparent power, and K_u is sudden voltage reduction factor. The acceptable voltage dips limiting value is <3%.

3) Flicker The measurements are made for maximum number of specified switching operation of wind turbine with 10- min period and 2-h period are specified, as given in Eq. 3.

$$P_u = c (\psi k) s_n / s_k \quad (3)$$

Where P_u —Long term flicker.



$c (\psi k)$ —Flicker coefficient The Limiting Value for flicker coefficient is about ≤ 0.4 , for average time of 2 h.

4)Harmonics The harmonic distortion is assessed for variable speed turbine with a electronic power converter at the point of common connection. The total harmonic voltage distortion of voltage is given as in Eq. 4.

$$V_{THD} = \sqrt{\sum_{h=2}^{40} \frac{V_h^2}{V_1^2}} 100 \tag{4}$$

Where V_n is the n th harmonic voltage and V_1 is the fundamental frequency (50) Hz. The THD limit for 132 KV is $< 3\%$.

$$I_{THD} = \sqrt{\sum \frac{I_h}{I_1}} 100 \tag{5}$$

GRID FREQUENCY The grid frequency in India is specified in the range of 47.5–51.5 Hz, for wind farm connection.

III. PROPOSED METHOD

The STATCOM based current control voltage source inverter injects the current into the grid will cancel out the reactive part and harmonic part of the load and induction generator current, thus it improves the power factor and the power quality. To accomplish these goals, the grid voltages are sensed and are synchronized in generating the current. The proposed grid connected system is implemented for power quality

improvement at point of common coupling (PCC), for grid connected system in Fig.1

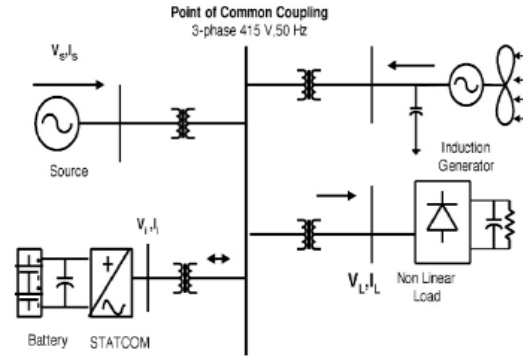

Fig.1. Grid conncted system for power quality improvement.

A.WIND ENERGY GENERATING SYSTEM:

In this configuration, wind generations are based on constant speed topologies with pitch control turbine The induction generator is used in the proposed scheme because of its simplicity, it does not require a separate field circuit, it can accept constant and variable loads, and has natural protection against short circuit. The available power of wind energy system is presented as under in Eq.6..

$$P_{wind} = \frac{1}{2} \rho A V_{wind}^3 \tag{6}$$

Where ρ (kg/m) is the air density and A (m) is the area swept out by turbine blade, V_{wind} is the wind speed in mtr/s. It is not possible to extract all kinetic energy of wind, thus it extract a fraction of power in wind, called power coefficient C_p of the wind turbine, and is given in Eq.

$$P_{mech} = C_p P_{wind} \tag{7}$$



Where C_p is the power coefficient, depends on type and operating condition of wind turbine. This coefficient can be express as a function of tip speed ratio γ and θ pitch angle. The mechanical power produce by wind turbine is given in Eq. 8.

$$P_{mech} = \frac{1}{2} \rho \pi R^2 V_{wind}^3 C_p \quad (8)$$

Where R is the radius of the blade (m).

B.STATCOM-STATIC SYNCHRONOUS COMPENSATOR

The STATCOM (or SSC) is a shunt-connected reactive-power compensation device that is capable of generating and/ or absorbing reactive power and in which the output can be varied to control the specific parameters of an electric power system. In general it is solid state switching converter which is capable of generating or absorbing independently controllable real and reactive power at its output terminals when it is fed from an energy source at its input terminals. Specifically, the STATCOM considered in this is a voltage-source converter from a given input of dc voltage produces a set of 3-phase ac-output voltages, each in phase with and coupled to the corresponding ac system voltage through leakage reactance. The dc voltage is provided by an energy-storage capacitor.

A STATCOM can improve power-system performance in such areas as the following:

1. The dynamic voltage control in Transmission and distribution systems;
2. The power-oscillation damping in power transmission systems;
3. The transient stability;
4. The voltage flicker control; and
5. It also controls real power in line when it is needed.

Advantages

- 1) It occupies small areas.
- 2) It replaces the large passive banks and circuit elements by compact converters.
- 3) Reduces site work and time.
- 4) Its response is very fast.

BESS-STATCOM: The battery energy storage system (BESS) is used as an energy storage element for the purpose of voltage regulation. The BESS will naturally maintain dc capacitor voltage constant and is best suited in STATCOM since it rapidly injects or absorbed reactive power to stabilize the grid system. It also control the distribution and transmission system in a very fast rate. When power fluctuation occurs in the system, the BESS can be used to level the power fluctuation by charging and discharging operation. The battery is connected in parallel to the dc capacitor of STATCOM.

The STATCOM is a three-phase voltage source inverter having the capacitance on its DC link and connected at the point of common coupling. The STATCOM injects a compensating current of variable



magnitude and frequency component at the bus of common coupling.

System Operation: The shunt connected STATCOM with battery energy storage is connected with the interface of the induction generator and non-linear load at the PCC in the grid system. The STATCOM compensator output is varied according to the controlled strategy, so as to maintain the power quality norms in the grid system. The current control strategy is included in the control.

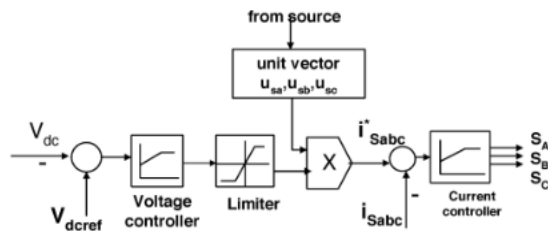

Fig.2. Control scheme.

IV. SIMULATION RESULTS

The proposed control scheme is simulated using SIMULINK in power system block set. The system parameter for given system is given Table I. The system performance of proposed system under dynamic condition is also presented.

s.no	Parameter	Rating
1	Grid Voltage	3-phase,415V,50Hz
2	Induction motor/generator	3.35KVA, 415V,50Hz,P=4,Speed=1440rpm, Rr=0.01Ω, Rs=0.015Ω, Ls=Lr=0.06H

3	Line series inductance	0.05mH
4	Inverter Parameters	DC Link Voltage=800V, DC Link Capacitance =100μF, Switching Frequency=2kHz
5	IGBT rating	Collector Voltage=1200V, Forward Current =50A, Gate Voltage=20V, Power Dissipation=310W
6	Load Parameter	Non-Linear Load=25kw

Voltage Source Current Control— Inverter Operation

The three phase injected current into the grid from STATCOM will cancel out the distortion caused by the nonlinear load and wind generator. The IGBT based three-phase inverter is connected to grid through the transformer. The generation of switching signals from reference current is simulated within hysteresis band of 0.08. The choice of narrow hysteresis band switching in the system improves the current quality. The control signal of switching frequency within its operating band, as shown in Fig. 4. The choice of the current band depends on the operating voltage and the interfacing transformer impedance. The compensated current for



the nonlinear load and demanded reactive power is provided by the inverter. The real power transfer from the battery is also supported by the controller of this inverter. The three phase inverter injected current are shown in Fig. 5.

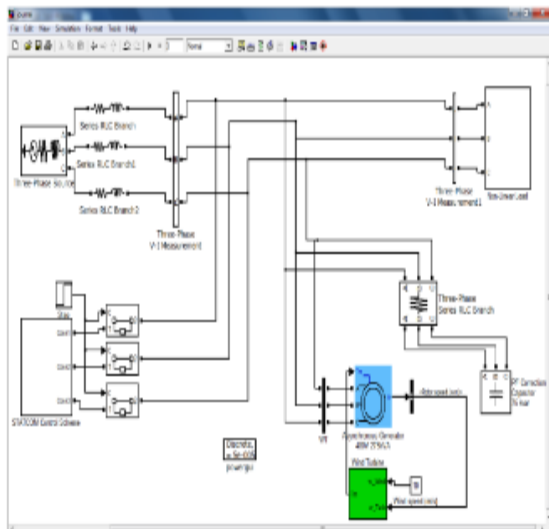

Fig.3. proposed control scheme with STATCOM

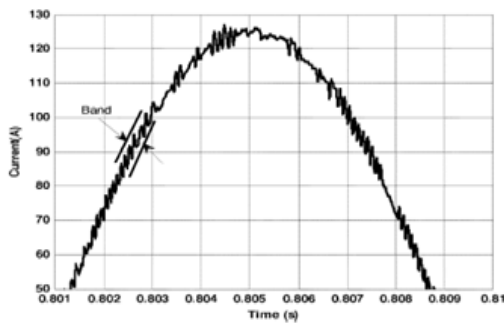

Fig.4. Switching signal within a control hysteresis band.

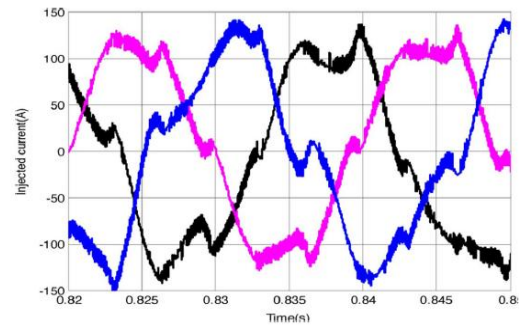

Fig.5. Three phase injected inverter current.

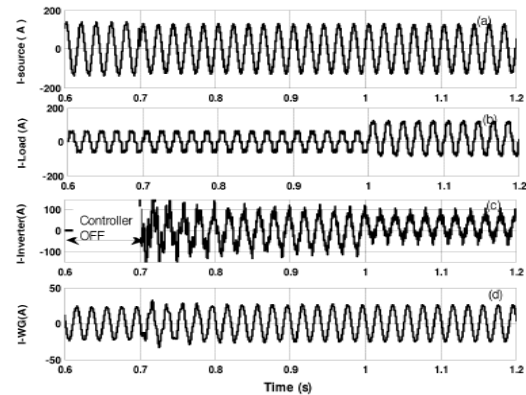

Fig. 6. (a) Source Current. (b) Load Current. (c) Inverter Injected Current.(d) Wind generator (Induction generator) current.

The DC link voltage regulates the source current in the grid system, so the DC link voltage is maintained constant across the capacitor as shown in Fig. 7(a). The current through the dc link capacitor indicating the charging and discharging operation as shown in Fig.7(b)

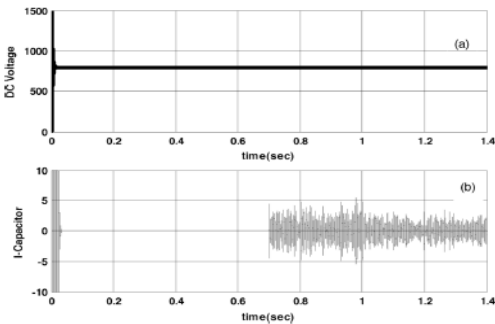

Fig.7. DC link voltage Current through capacitor.

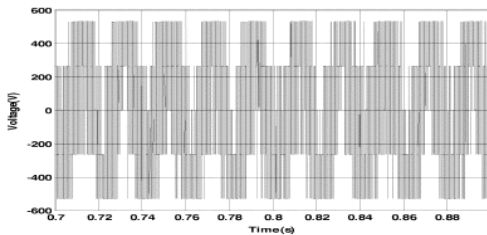

Fig.8. STATCOM output voltage.

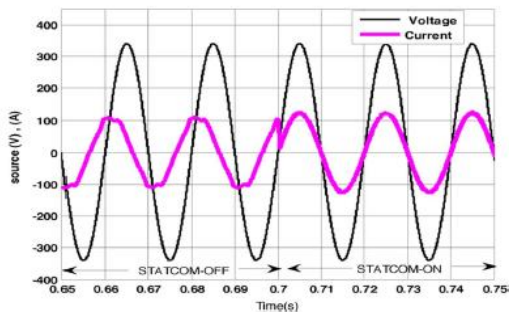

Fig.9. Supply voltage and current at PCC.

Power Quality Improvement

It is observed that the source current on the grid is affected due to the effects of nonlinear load and wind generator, thus purity of waveform may be lost on both sides in the system. The inverter output

voltage under STATCOM operation with load variation is shown in Fig. 8. The dynamic load does affect the inverter output voltage. The source current with and without STATCOM operation is shown in Fig. 9. This shows that the unity power factor is maintained for the source power when the STATCOM is in operation.

V. CONCLUSION

This paper analyze the factors of the power quality problems in the renewable energy sources conversion system and implementation of proper control scheme for power quality improvement in the wind energy conversion system in the grid. These grid connected energy conversion system for power quality improvement is simulated by using MATLAB/SIMULINK. These control system schemes are used to cancel the harmonics parts of the load current. The quality maintains the source voltage and current in each phase and supports the active and reactive power demand for the wind generator and load at PCC in the grid system to enhance the utilization factor of transmission lines.

REFERENCE

- [1] A. Sannino, "Global power systems for sustainable development," in IEEE General Meeting, Denver, CO, Jun. 2004.
- [2] K. S. Hook, Y. Liu, and S. Atcitty, "Mitigation of the wind generation integration related power quality issues by energy storage," EPQU J., vol. XII, no. 2, 2006.



- [3] R. Billinton and Y. Gao, "Energy conversion system models for adequacy assessment of generating systems incorporating wind energy," *IEEE Trans. on E. Conv.*, vol. 23, no. 1, pp. 163–169, 2008, Multistate.
- [4] Wind Turbine Generating System—Part 21, International standard-IEC61400-21, 2001.
- [5] J. Manel, "Power electronic system for grid integration of renewable energy source: A survey," *IEEE Trans. Ind. Electron.*, vol. 53, no. 4, pp. 1002–1014, 2006, Carrasco.
- [6] M. Tsili and S. Papathanassiou, "A review of grid code technology requirements for wind turbine," *Proc. IET Renew. power gen.*, vol. 3, pp. 308–332, 2009.
- [7] S. Heier, *Grid Integration of Wind Energy Conversions*. Hoboken, NJ: Wiley, 2007, pp. 256–259.
- [8] J. J. Gutierrez, J. Ruiz, L. Leturiondo, and A. Lazkano, "Flicker measurement system for wind turbine certification," *IEEE Trans. Instrum. Meas.*, vol. 58, no. 2, pp. 375–382, Feb. 2009.
- [9] Indian Wind Grid Code Draft report on, Jul. 2009, pp. 15–18, C-NET.
- [10] S. Heier —*Grid Integration of Wind Energy Conversions*, || Hoboken, NJ: Wiley, 2007.

AUTHORS PROFILE:



T.Vani, M.Tech Student, Dept of EEE, SVEC, Suryapet, Hyderabad, Telangana state, India.



Venugopal Reddy Bodha received the B.Tech degree in electrical engineering from jntu Hyderabad in 2007, M.Tech in power electronics from jntu hyderabad in 2012, and currently he is working as an assistant professor in EEE dept at SV Engineering College, suryapet His research interests include, active power filters, power converters distributed power systems and power factor-correction circuits.